



浩畅半导体
www.szhaochang.cn

FMMT491 TRANSISTOR (NPN)

SOT-23 Plastic-Encapsulate Transistors

产
品
规
格
书

承
认
书

客户确认：

公司签章：

部门	工程部	品保部	采购部
签名			
日期			



SOT-23 Plastic-Encapsulate Transistors

FMMT491 TRANSISTOR (NPN)

FEATURES

Low equivalent on-resistance

Marking :491

MAXIMUM RATINGS($T_A=25^{\circ}\text{C}$ unless otherwise noted)

Symbol	Parameter	Value	Units
V_{CB0}	Collector-Base Voltage	80	V
V_{CEO}	Collector-Emitter Voltage	60	V
V_{EBO}	Emitter-Base Voltage	5	V
I_C	Collector Current -Continuous	1	A
P_C	Collector Power Dissipation	250	mW
T_j	Junction Temperature	150	$^{\circ}\text{C}$
T_{stg}	Storage Temperature	-55-150	$^{\circ}\text{C}$

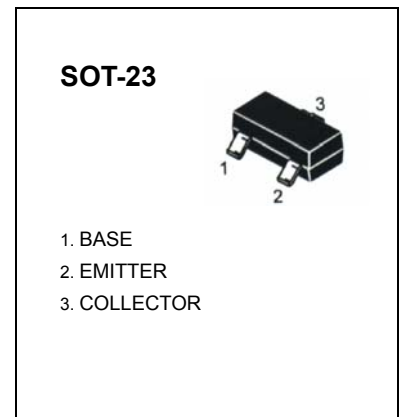

ELECTRICAL CHARACTERISTICS ($T_{amb}=25^{\circ}\text{C}$ unless otherwise specified)

Parameter	Symbol	Test conditions	MIN	TYP	MAX	UNIT
Collector-base breakdown voltage	$V_{(BR)CBO}$	$I_C=100\mu\text{A}, I_E=0$	80			V
Collector-emitter breakdown voltage	$V_{(BR)CEO}^1$	$I_C=10\text{mA}, I_B=0$	60			V
Emitter-base breakdown voltage	$V_{(BR)EBO}$	$I_E=100\mu\text{A}, I_C=0$	5			V
Collector cut-off current	I_{CBO}	$V_{CB}=60\text{V}, I_E=0$			0.1	μA
Emitter cut-off current	I_{EBO}	$V_{EB}=4\text{V}, I_C=0$			0.1	μA
DC current gain	$h_{FE(1)}$	$V_{CE}=5\text{V}, I_C=1\text{mA}$	100			
	$h_{FE(2)}^1$	$V_{CE}=5\text{V}, I_C=500\text{mA}$	100		300	
	$h_{FE(3)}^1$	$V_{CE}=5\text{V}, I_C=1\text{A}$	80			
	$h_{FE(4)}^1$	$V_{CE}=5\text{V}, I_C=2\text{A}$	30			
Collector-emitter saturation voltage	$V_{CE(sat)1}^1$	$I_C=500\text{mA}, I_B=50\text{mA}$			0.25	V
	$V_{CE(sat)2}^1$	$I_C=1\text{A}, I_B=100\text{mA}$			0.5	V
Base-emitter saturation voltage	$V_{BE(sat)}^1$	$I_C=1\text{A}, I_B=100\text{mA}$			1.1	V
Base-emitter voltage	V_{BE}^1	$V_{CE}=5\text{V}, I_C=1\text{A}$			1	V
Transition frequency	f_T	$V_{CE}=10\text{V}, I_C=50\text{mA}, f=100\text{MHz}$	150			MHz
Collector output capacitance	C_{ob}	$V_{CB}=10\text{V}, f=1\text{MHz}$			10	pF

¹Measured under pulsed conditions, Pulse width=300 μs , Duty cycle \leq 2%.

Typical Characteristics

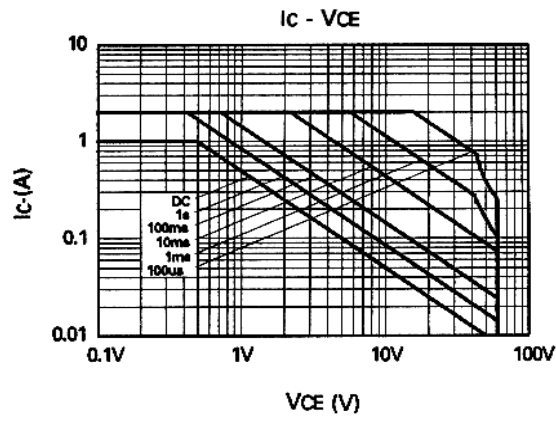
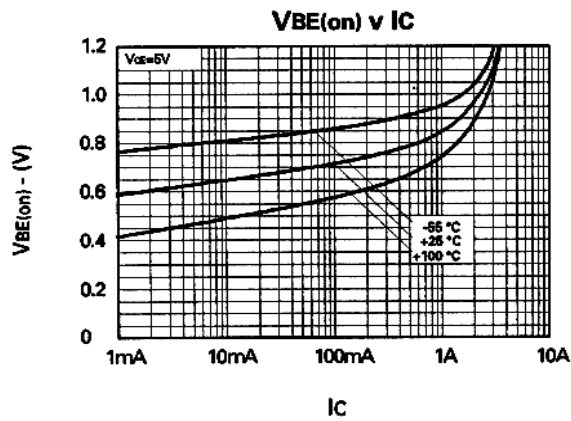
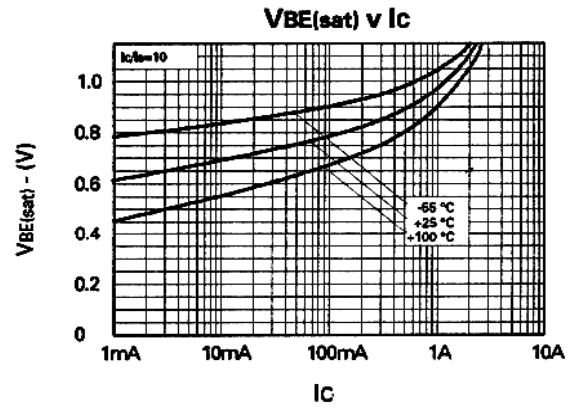
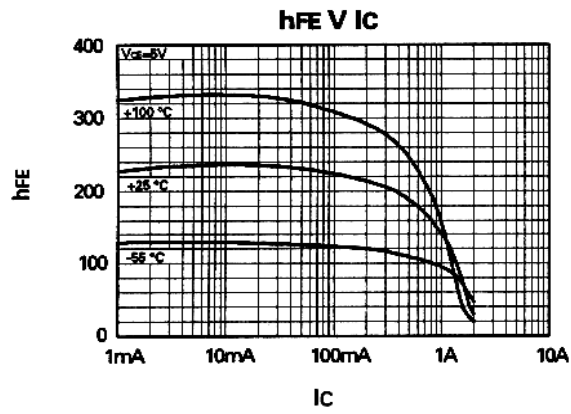
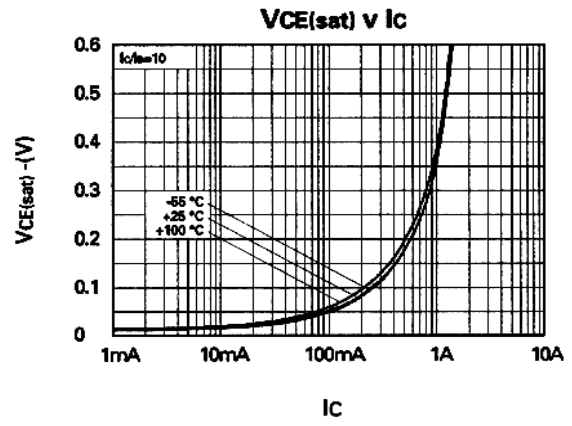
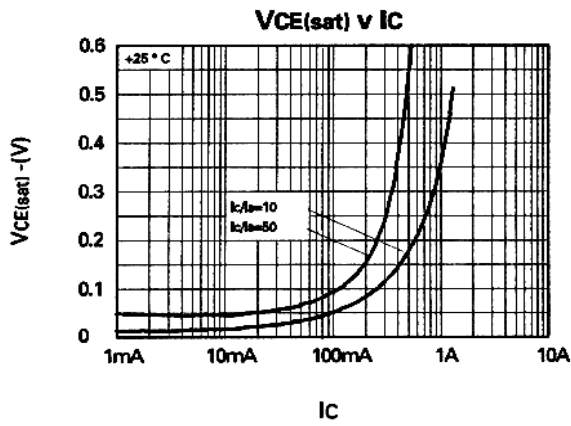

SOT-23 Package Outline Dimensions

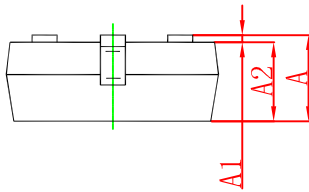
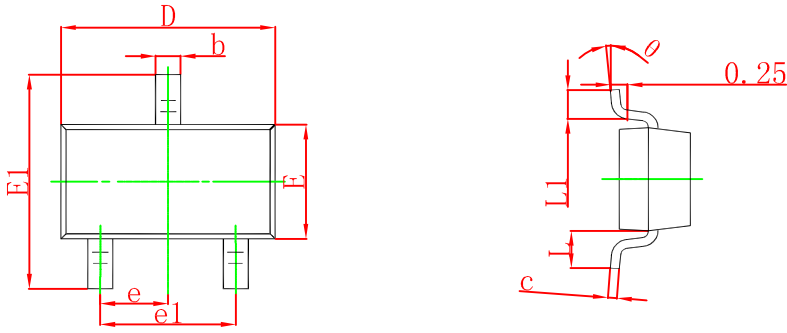

Symbol	Dimensions In Millimeters		Dimensions In Inches	
	Min	Max	Min	Max
A	0.900	1.150	0.035	0.045
A1	0.000	0.100	0.000	0.004
A2	0.900	1.050	0.035	0.041
b	0.300	0.500	0.012	0.020
c	0.080	0.150	0.003	0.006
D	2.800	3.000	0.110	0.118
E	1.200	1.400	0.047	0.055
E1	2.250	2.550	0.089	0.100
e	0.950 TYP		0.037 TYP	
e1	1.800	2.000	0.071	0.079
L	0.550 REF		0.022 REF	
L1	0.300	0.500	0.012	0.020
θ	0°	8°	0°	8°

SOT-23 Suggested Pad Layout

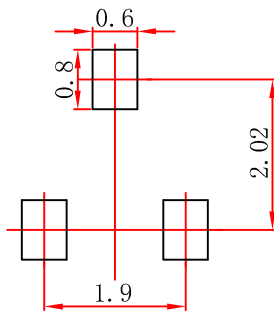

Note:

1. Controlling dimension: in millimeters.
2. General tolerance: ± 0.05 mm.
3. The pad layout is for reference purposes only.