



浩畅半导体
www.szhaochang.cn

MMBTA44 TRANSISTOR (NPN)

SOT-23 Plastic-Encapsulate Transistors

产
品
规
格
书

承
认
书

客户确认：

公司签章：

部门

工程部

品保部

采购部

签名

日期



SOT-23 Plastic-Encapsulate Transistors

MMBTA44 TRANSISTOR (NPN)

FEATURES

- High Collector-Emitter Voltage
- Complement to MMBTA94

MARKING: 3D

MAXIMUM RATINGS (T_a=25°C unless otherwise noted)

Symbol	Parameter	Value	Unit
V _{CBO}	Collector-Base Voltage	500	V
V _{CEO}	Collector-Emitter Voltage	400	V
V _{EBO}	Emitter-Base Voltage	6	V
I _C	Collector Current	100	mA
P _C	Collector Power Dissipation	350	mW
R _{θJA}	Thermal Resistance From Junction To Ambient	357	°C/W
T _J	Junction Temperature	150	°C
T _{stg}	Storage Temperature	-55~+150	°C

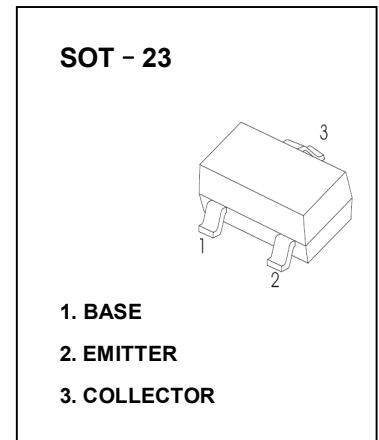

ELECTRICAL CHARACTERISTICS (T_a=25°C unless otherwise specified)

Parameter	Symbol	Test conditions	Min	Typ	Max	Unit
Collector-base breakdown voltage	V _{(BR)CBO}	I _C =100μA, I _E =0	500			V
Collector-emitter breakdown voltage	V _{(BR)CEO} *	I _C =1mA, I _B =0	400			V
Emitter-base breakdown voltage	V _{(BR)EBO}	I _E =10μA, I _C =0	6			V
Collector cut-off current	I _{CBO}	V _{CB} =400V, I _E =0			0.1	μA
Emitter cut-off current	I _{EBO}	V _{EB} =4V, I _C =0			0.1	μA
DC current gain	h _{FE(1)} *	V _{CE} =10V, I _C =1mA	40			
	h _{FE(2)} *	V _{CE} =10V, I _C =10mA	50		200	
	h _{FE(3)} *	V _{CE} =10V, I _C =50mA	45			
	h _{FE(4)} *	V _{CE} =10V, I _C =100mA	40			
Collector-emitter saturation voltage	V _{CE(sat)1} *	I _C =1mA, I _B =0.1mA			0.4	V
	V _{CE(sat)2} *	I _C =10mA, I _B =1mA			0.5	V
	V _{CE(sat)3} *	I _C =50mA, I _B =5mA			0.75	V
Base-emitter saturation voltage	V _{BE(sat)} *	I _C =10mA, I _B =1mA			0.75	V
Collector output capacitance	C _{ob}	V _{CB} =20V, I _E =0, f=1MHz			7	pF
Emitter input capacitance	C _{ib}	V _{EB} =0.5V, I _C =0, f=1MHz			130	pF

*Pulse test: pulse width ≤300μs, duty cycles ≤ 2.0%.

Typical Characteristics

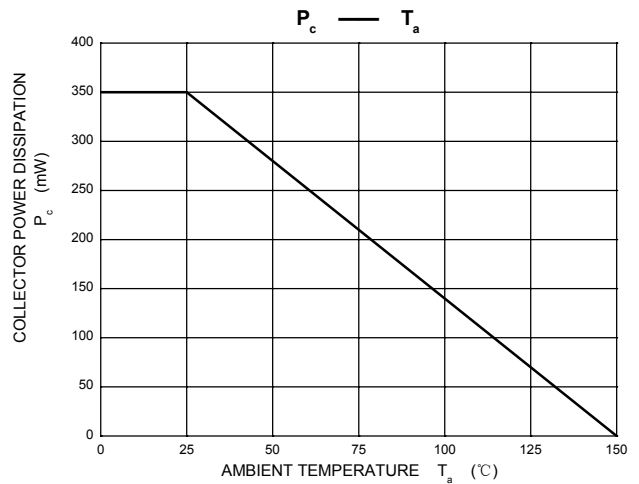
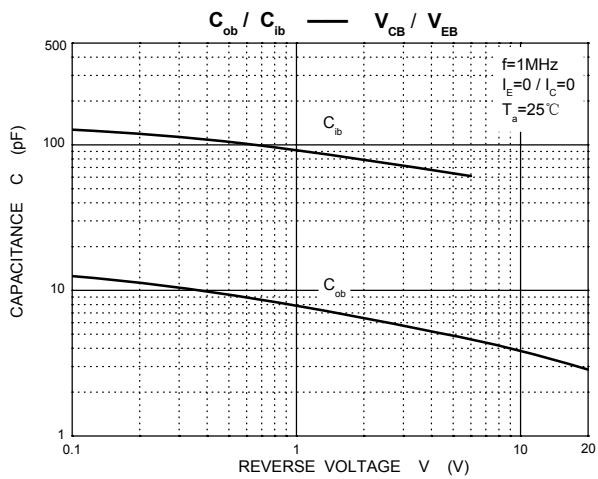
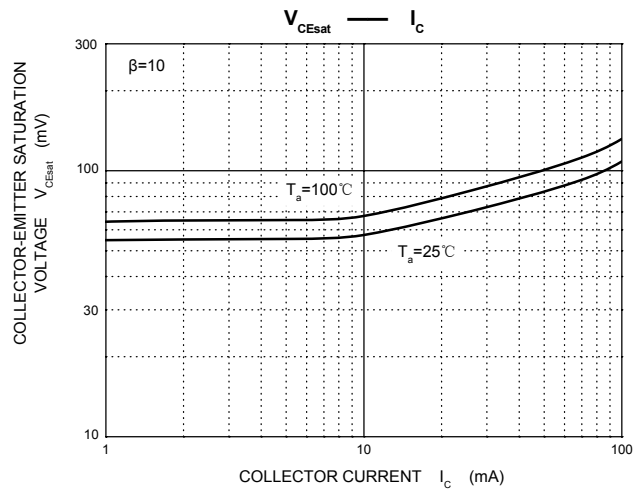
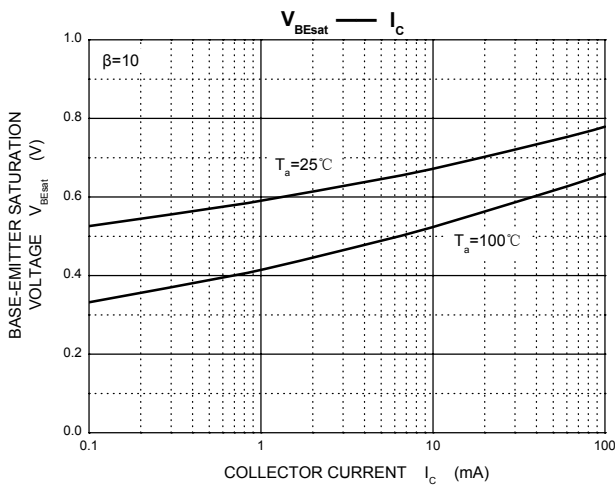
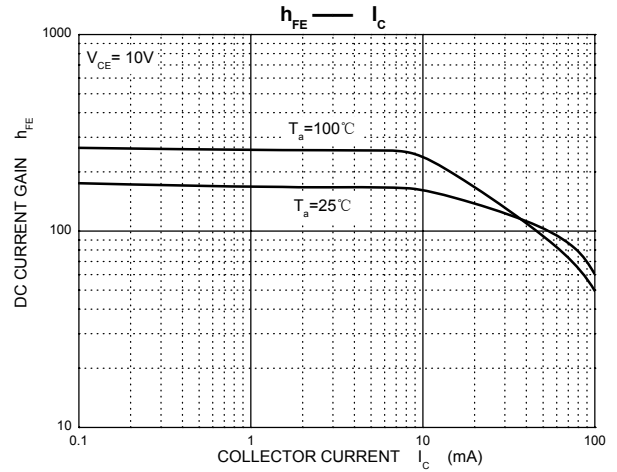
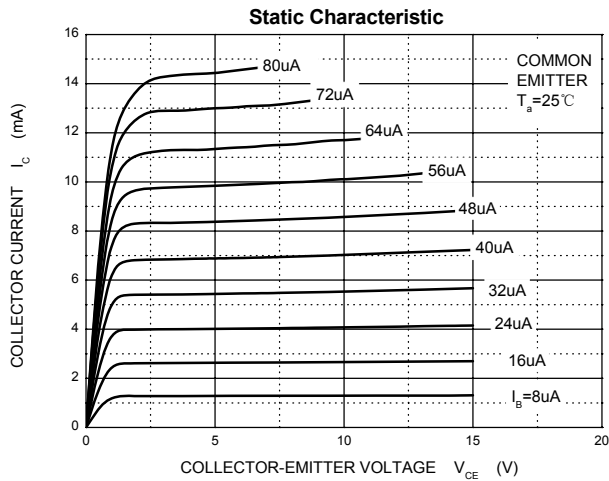

SOT-23 Package Outline Dimensions

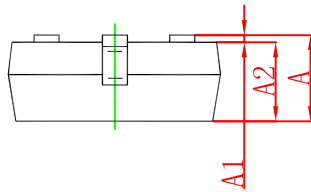

Symbol	Dimensions In Millimeters		Dimensions In Inches	
	Min	Max	Min	Max
A	0.900	1.150	0.035	0.045
A1	0.000	0.100	0.000	0.004
A2	0.900	1.050	0.035	0.041
b	0.300	0.500	0.012	0.020
c	0.080	0.150	0.003	0.006
D	2.800	3.000	0.110	0.118
E	1.200	1.400	0.047	0.055
E1	2.250	2.550	0.089	0.100
e	0.950 TYP		0.037 TYP	
e1	1.800	2.000	0.071	0.079
L	0.550 REF		0.022 REF	
L1	0.300	0.500	0.012	0.020
θ	0°	8°	0°	8°

SOT-23 Suggested Pad Layout



Note:

1. Controlling dimension: in millimeters.
2. General tolerance: $\pm 0.05\text{mm}$.
3. The pad layout is for reference purposes only.