



浩畅半导体
www.szhaochang.cn

MMBD914 SWITCHING DIODE

SOT-23 Plastic-Encapsulate Diodes

产
品
规
格
书

承
认
书

客户确认：

公司签章：

部门	工程部	品保部	采购部
签名			
日期			



SOT-23 Plastic-Encapsulate Diodes

MMBD914 SWITCHING DIODE

FEATURES

High-Speed Switching Diode

MARKING: 5D

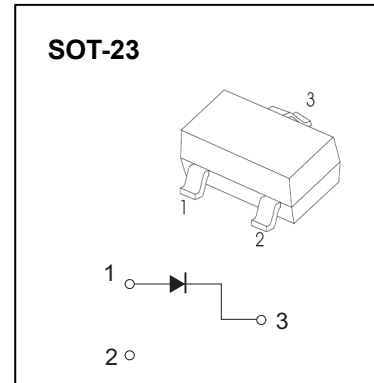
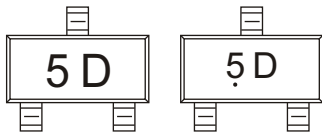

Solid dot = Green molding compound device,if none,the normal device.

Maximum Ratings @Ta=25°C

Parameter	Symbol	Limit	Unit
Non-Repetitive Peak Reverse Voltage	V_{RM}	100	V
Peak Repetitive Peak Reverse Voltage	V_{RRM}	100	V
Working Peak Reverse Voltage	V_{RWM}		
DC Blocking Voltage	V_R		
Average Rectified Output Current	I_O	300	mA
Non-Repetitive Peak Forward Surge Current @t=8.3ms	I_{FSM}	2	A
Power Dissipation	P_D	350	mW
Thermal Resistance Junction to Ambient	$R_{\theta JA}$	357	°C/W
Junction Temperature	T_j	150	°C
Storage Temperature	T_{STG}	-55~+150	°C

Electrical Characteristics@Ta=25°C

Parameter	Symbol	Min	Typ	Max	Unit	Conditions
Reverse Breakdown Voltage	$V_{(BR)}$	100			V	$I_R=100\mu A$
Forward Voltage	V_{F1}			715	mV	$I_F=1mA$
	V_{F2}			855	mV	$I_F=10mA$
	V_{F3}			1000	mV	$I_F=50mA$
	V_{F4}			1250	mV	$I_F=150mA$
Reverse Current	I_{R1}			1	uA	$V_R=75V$
	I_{R2}			25	nA	$V_R=20V$
Diode Capacitance	C_D			2	pF	$V_R=0, f=1MHz$
Reverse Recovery Time	t_{rr}			4	ns	$I_F = I_R = 10mA,$ $I_{rr} = 0.1 * I_R$

Typical Characteristics

Forward Characteristics

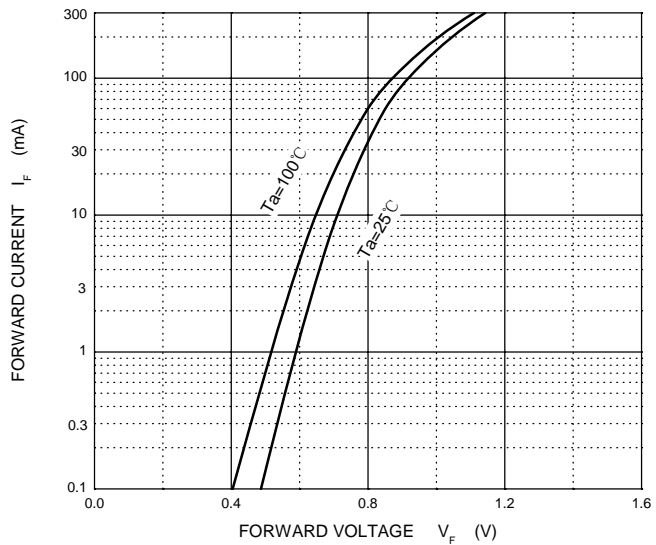

Reverse Characteristics

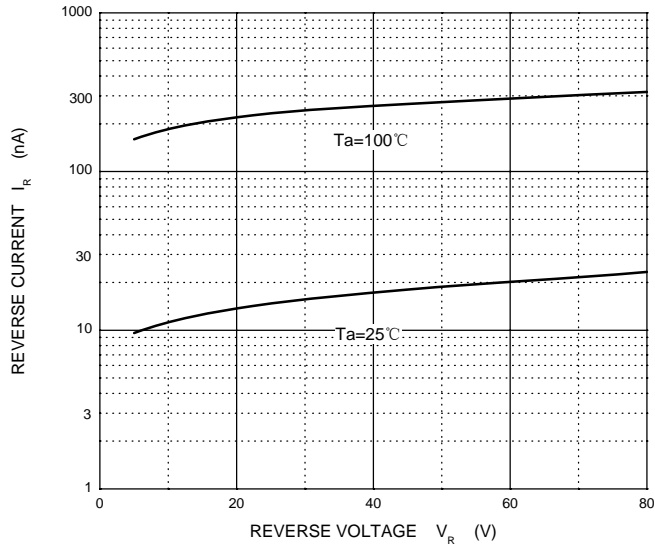

Capacitance Characteristics

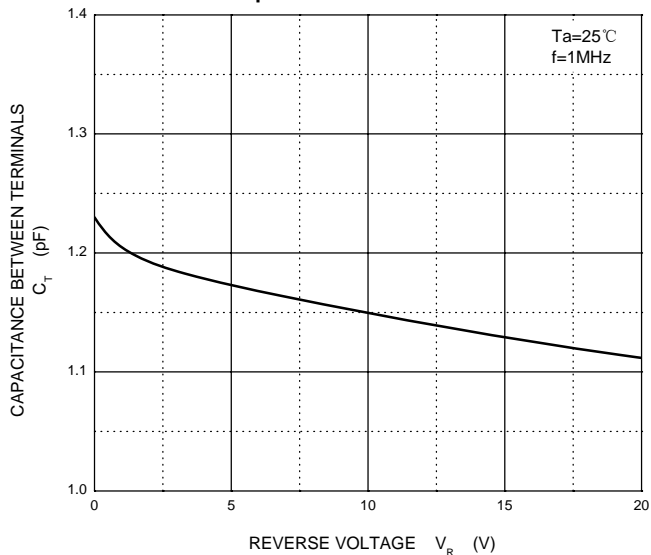

Power Derating Curve

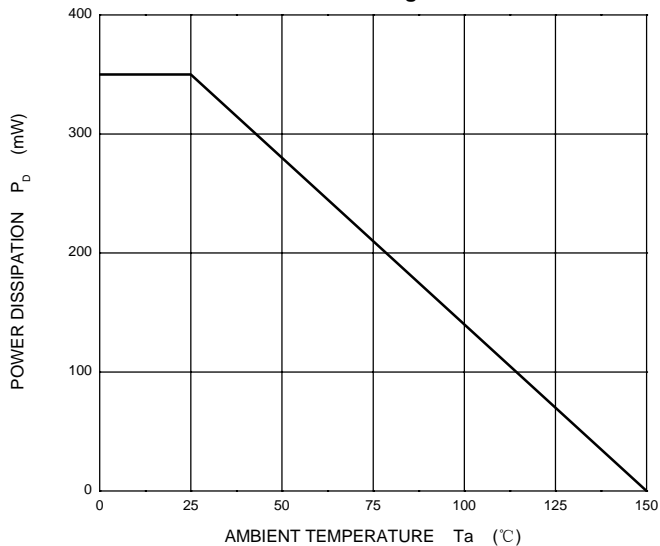

SOT-23 Package Outline Dimensions



Symbol	Dimensions In Millimeters		Dimensions In Inches	
	Min	Max	Min	Max
A	0.900	1.150	0.035	0.045
A1	0.000	0.100	0.000	0.004
A2	0.900	1.050	0.035	0.041
b	0.300	0.500	0.012	0.020
c	0.080	0.150	0.003	0.006
D	2.800	3.000	0.110	0.118
E	1.200	1.400	0.047	0.055
E1	2.250	2.550	0.089	0.100
e	0.950 TYP		0.037 TYP	
e1	1.800	2.000	0.071	0.079
L	0.550 REF		0.022 REF	
L1	0.300	0.500	0.012	0.020
θ	0°	8°	0°	8°

SOT-23 Suggested Pad Layout

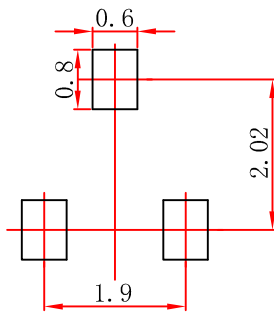

- Note:
1. Controlling dimension: in millimeters.
 2. General tolerance: $\pm 0.05\text{mm}$.
 3. The pad layout is for reference purposes only.